

Reviewed By:  
**REVIEWER**  
01/23/2017

Drawn By:  
**James Kenalty**  
01/29/2017

Project Start Date:  
09/20/2017

**Kenalty Fine Home Designs**  
3100 Fredericksburg Hwy.  
Kerrville, Texas 78028  
www.kenalty.com  
jim@kenalty.com  
280-899-2398

Copyright © 2014 - 2017 by Kenalty Fine Home Designs. All rights reserved.  
This drawing is the property of Kenalty Fine Home Designs and is not to be  
reproduced, stored in a retrieval system, or transmitted, in any form or by any means, electronic, mechanical, photocopying, recording, or by any other means, without the prior written consent of Kenalty Fine Home Designs. Kenalty Fine Home Designs is not responsible for any errors or omissions in this drawing. Kenalty Fine Home Designs provides this document "as is" without warranty of any kind, either implied or express, including but not limited to the implied warranties of merchantability and fitness for a particular purpose. Buyer Beware.

CUSTOM DESIGN FOR  
NAME OF CUSTOMER  
NAME OF REALTUTOR RANCH  
PROPERTY ADDRESS  
TOWN, TEXAS ZIP  
PHONE NUMBERS

Drawing Sealed By:

SCALE:  
AS NOTED

SECTIONS  
SHEET  
A - 4.2

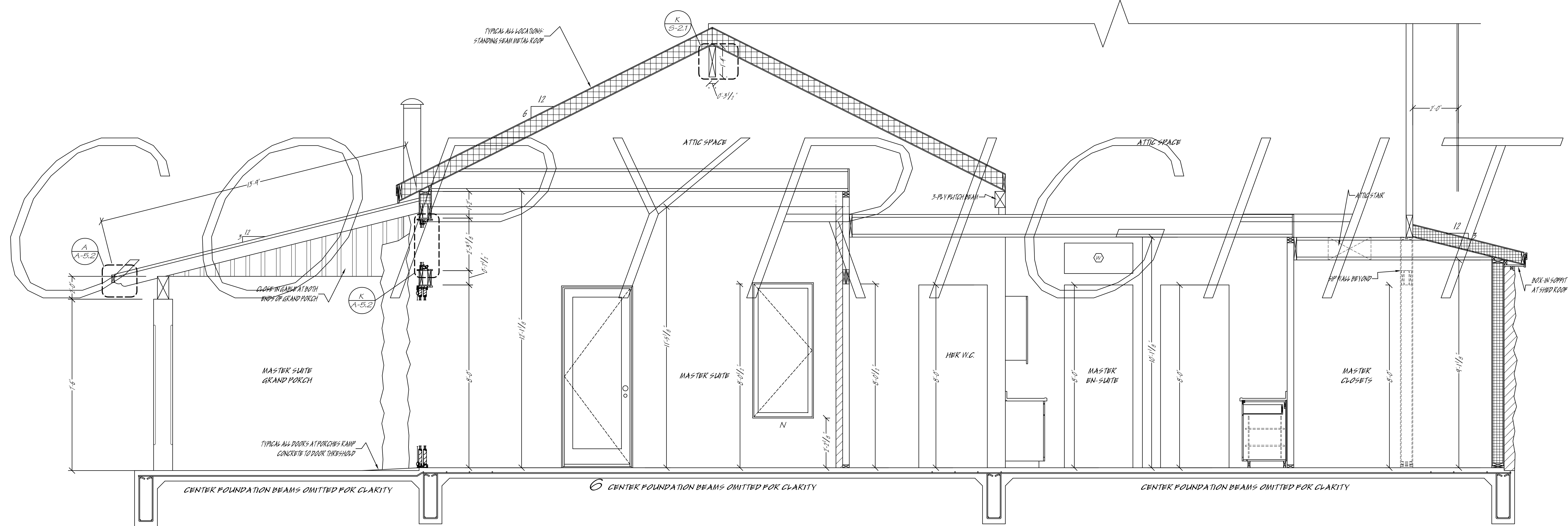

**F MASTER SUITE**  
1/2" - 1/8"

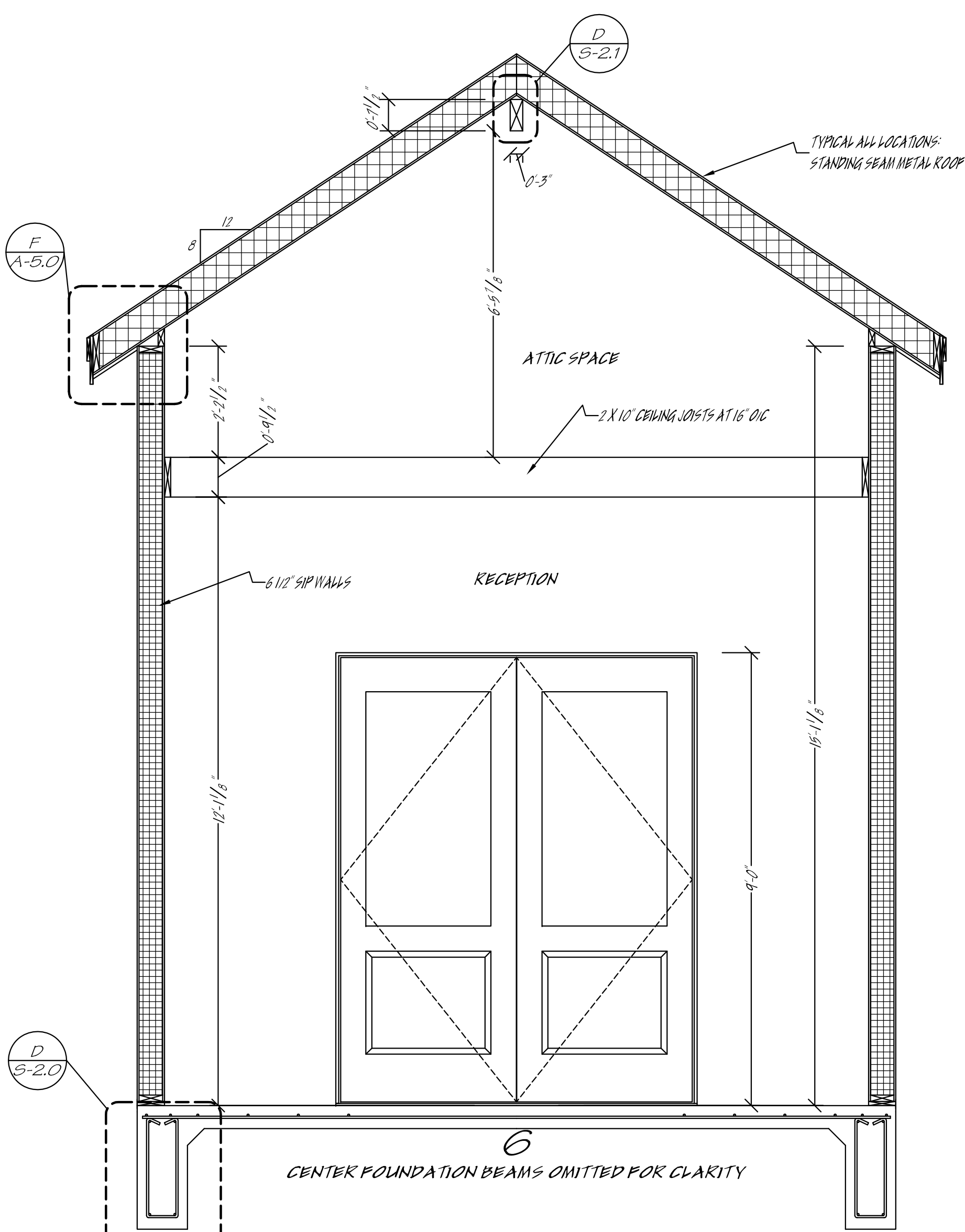

**H RECEPTION**  
1/2" - 1/8"

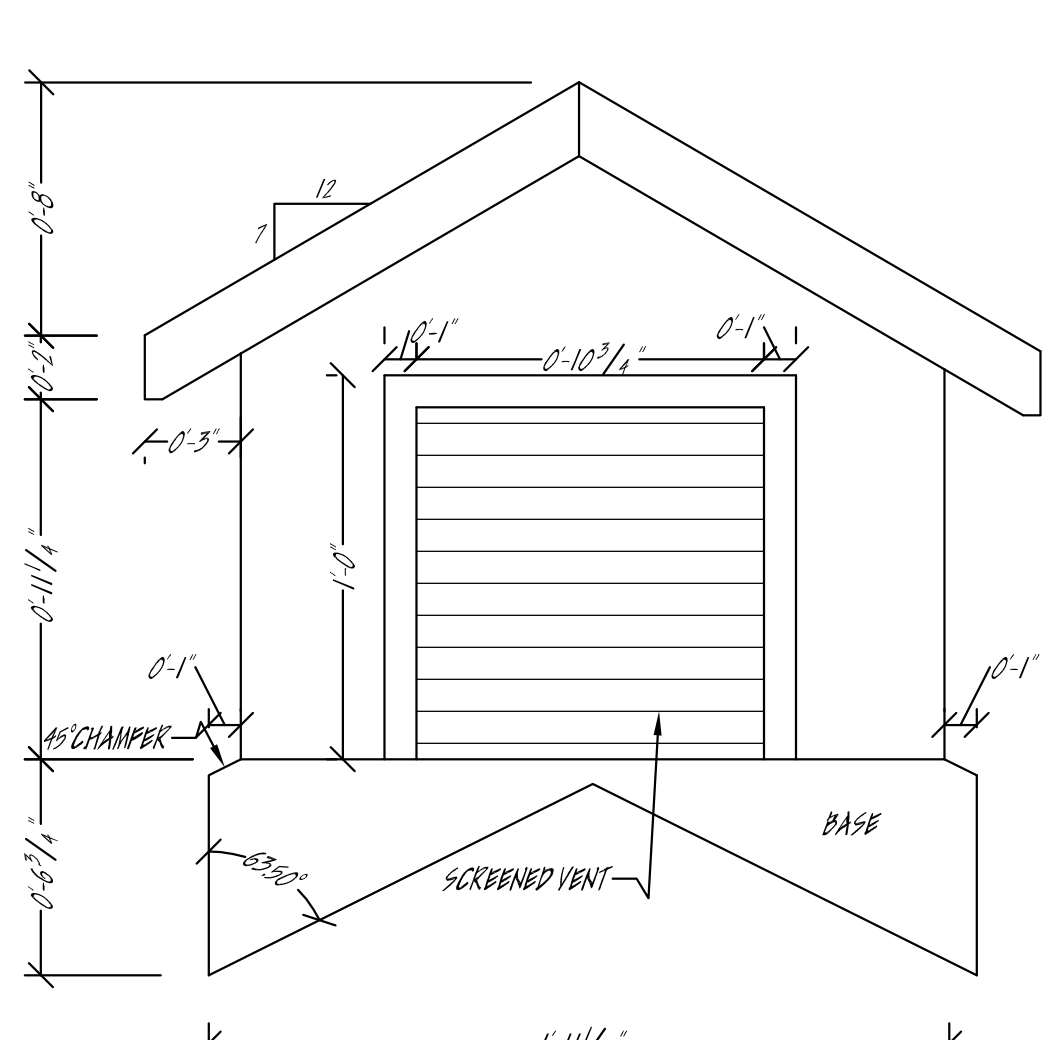

**A CUPOLA LATERAL**  
DETAIL  
0-2" - 1/8"

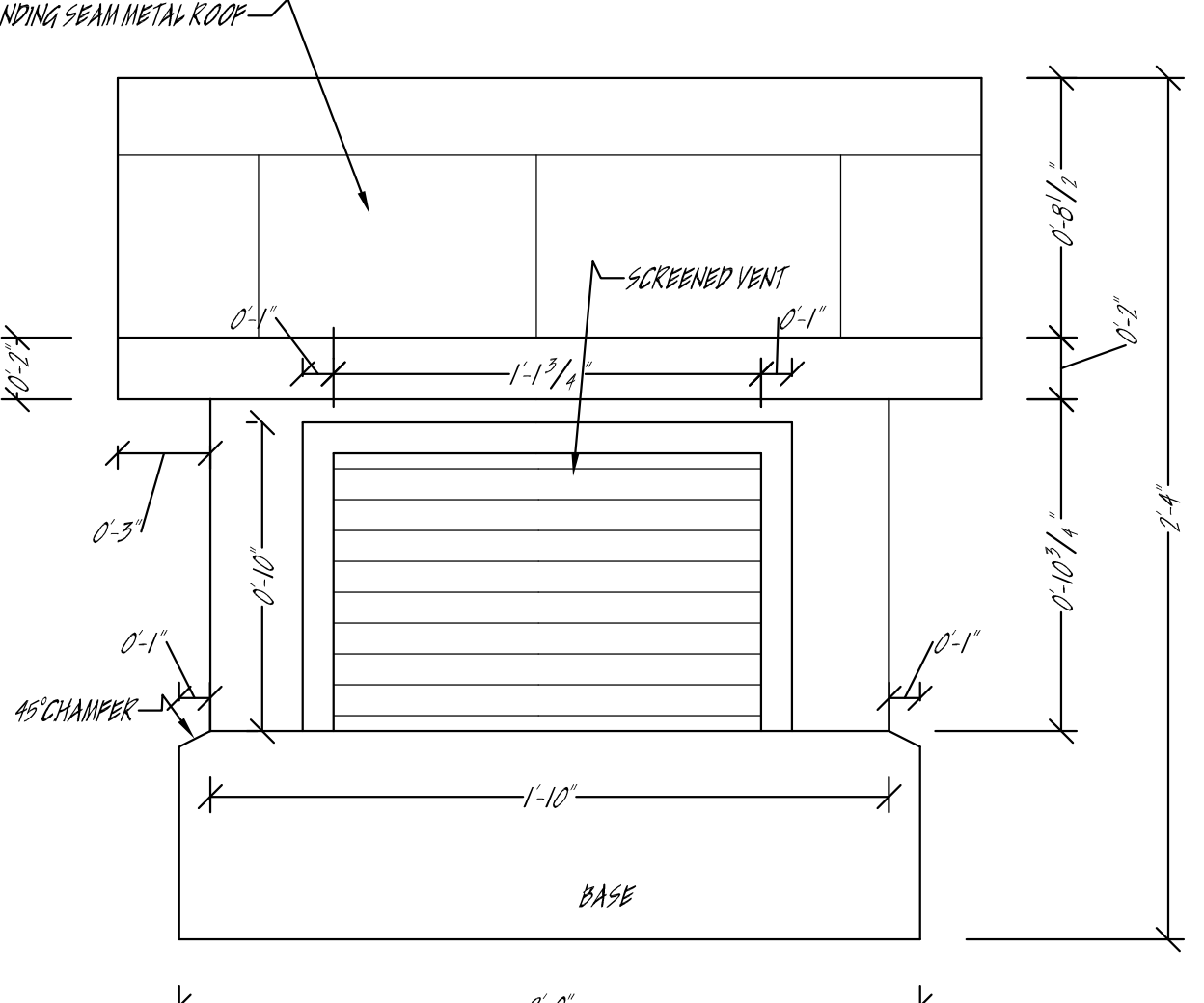

**B CUPOLA TRANSVERSE**  
DETAIL  
0-2" - 1/8"

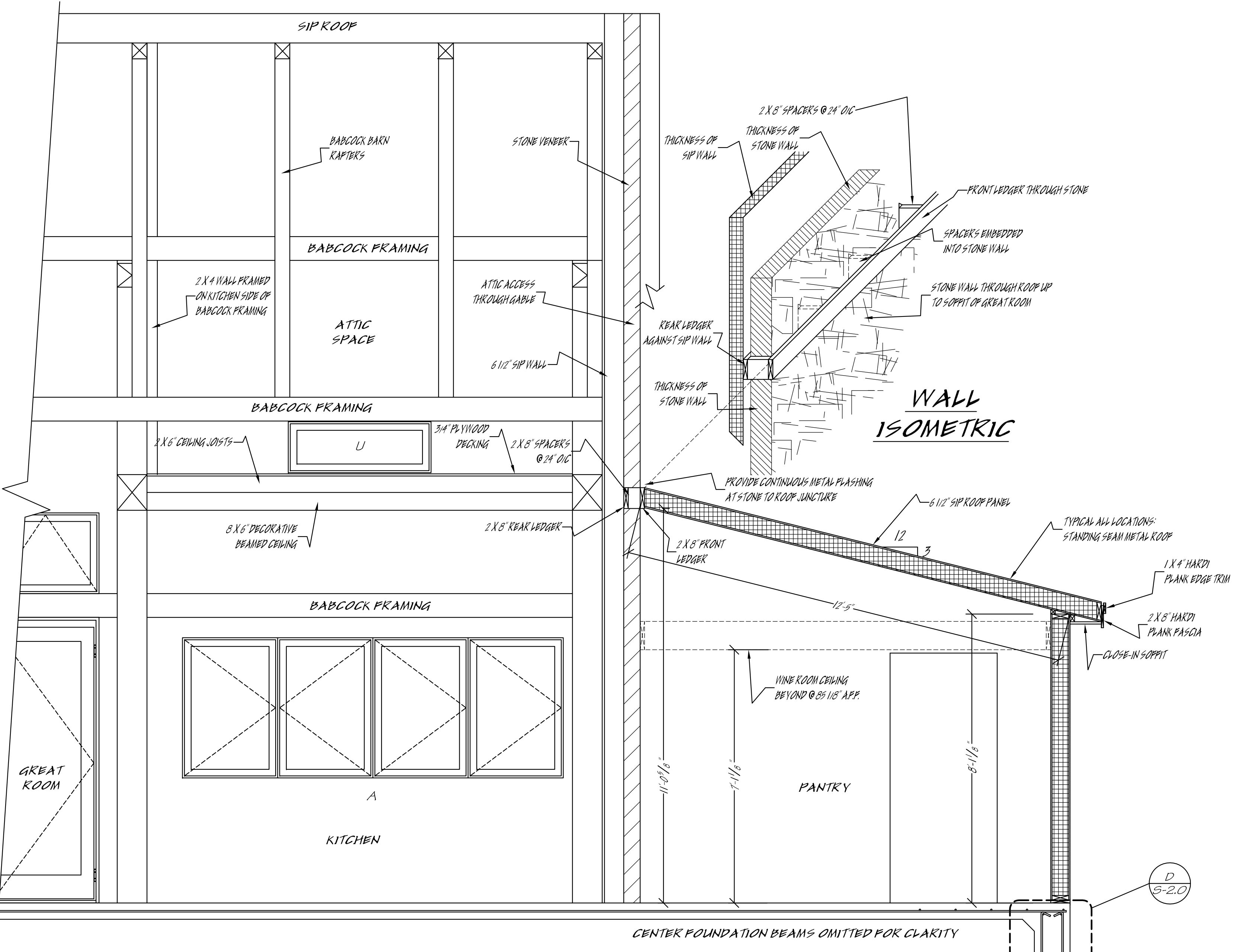

**WALL ISOMETRIC**

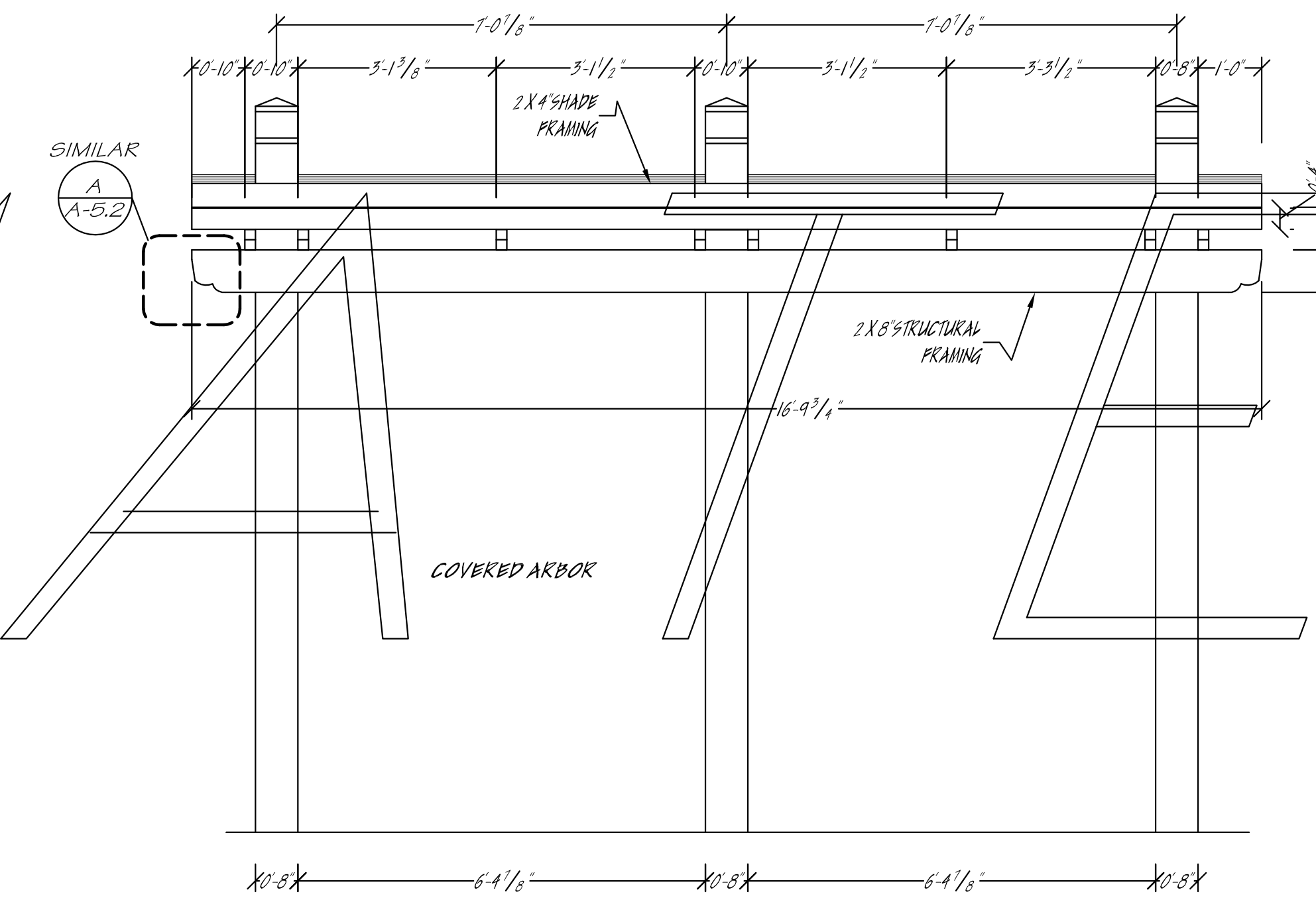

**K ARBOR LATERAL VIEW**  
1/2" - 1/8"

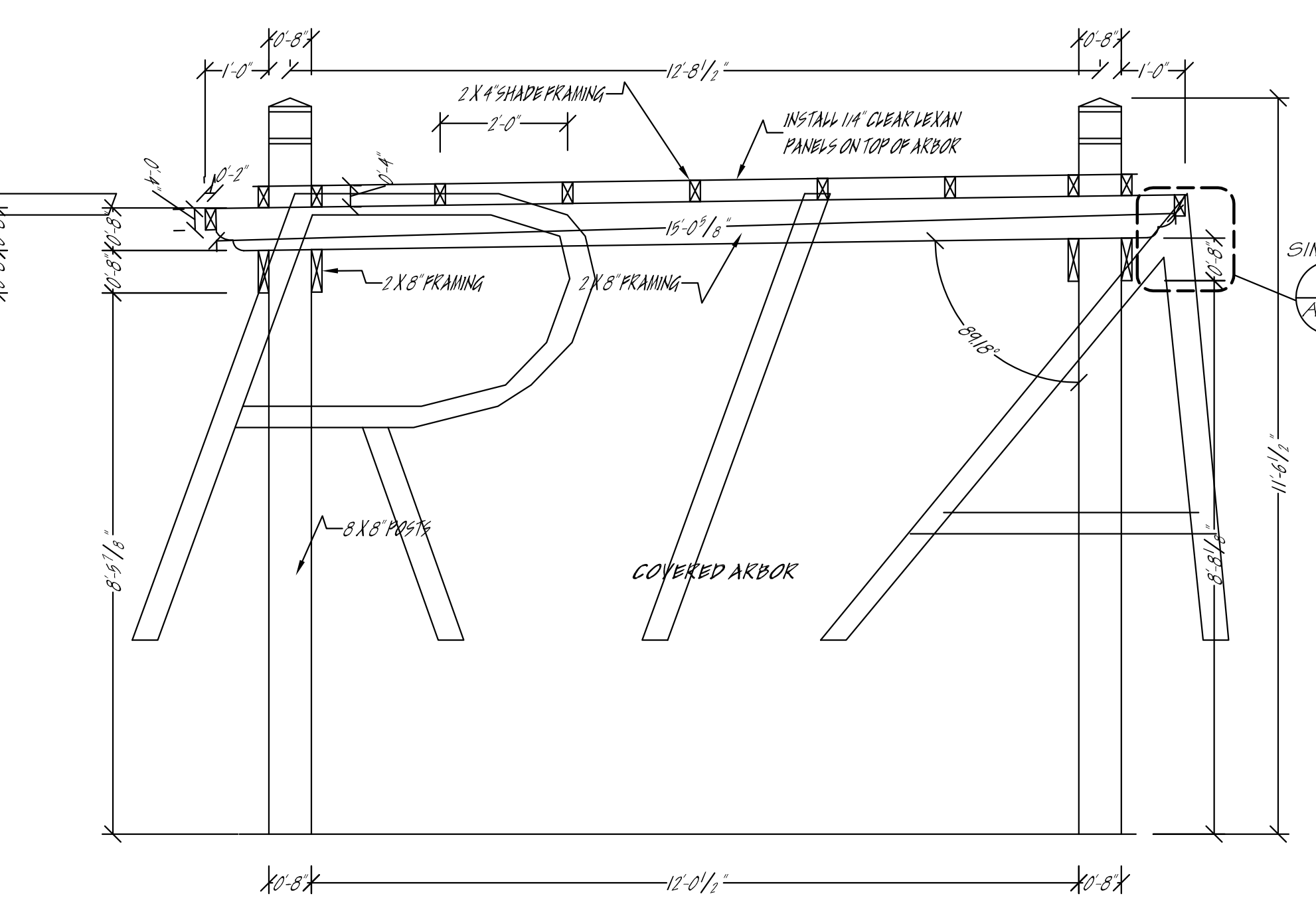

**L ARBOR TRANSVERSE VIEW**  
1/2" - 1/8"

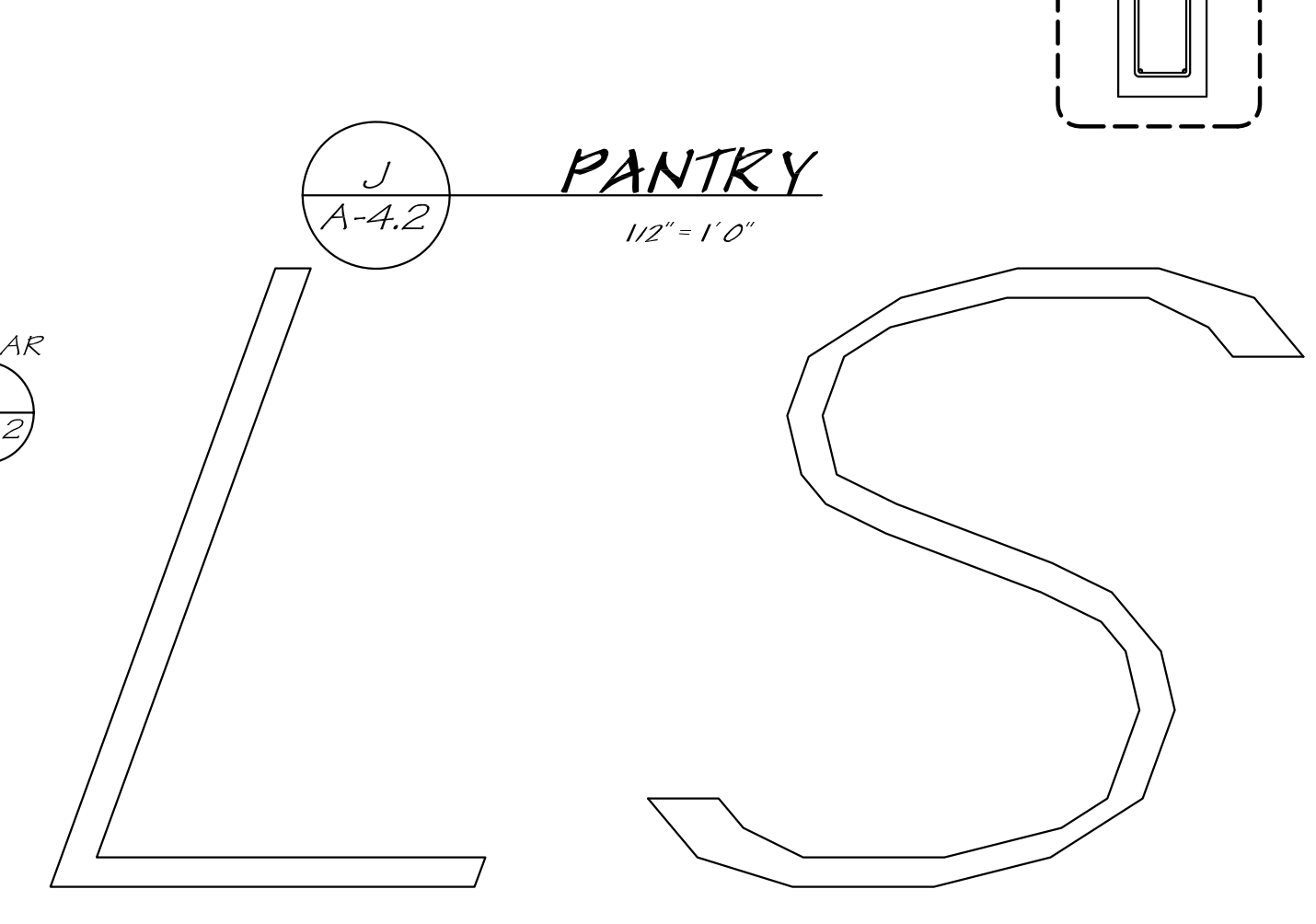

**J PANTRY**  
1/2" - 1/8"